

# Infrared Line Cameras **PYROLINE**

High-Speed Non-Contact Measurement Of Temperature Profiles

**0 °C to 3000 °C**





# PYROLINE

## High-Speed Uncooled Infrared Line Camera

The infrared line cameras **PYROLINE** allow you high-speed non-contact measurement of temperature profiles.

The cameras are specially designed for long-term use in fixed-mounted applications. For general purpose use the spectral ranges from 8  $\mu\text{m}$  to 14  $\mu\text{m}$  and 3  $\mu\text{m}$  to 5  $\mu\text{m}$  are available. The spectral ranges from 4.8  $\mu\text{m}$  to 5.2  $\mu\text{m}$  (which is particularly suitable for the measurement of temperature profiles in glass) and 0.8  $\mu\text{m}$  to 1.1  $\mu\text{m}$  (for metal) are for special applications.

With an uncooled infrared linear array (128, 256 or 512 pixels) you can realize non-contact measurement with 256 lines per second (512 lines per second optional) in temperature ranges from 0 °C to 3000 °C. The high-speed version PYROLINE HS 512N even provides 2000 lines per second. The camera has an aluminium compact-housing (IP54) or in a stainless steel industry protection housing IP65. More housing variants are available.

Different lenses with a field of view up to 90° are available. Measurement results can be transferred to your computer with real-time data transmission via fast ethernet with up to 2000 lines per second. Stand-alone operation without computer is possible too. Alarm and thresholding monitoring as well as triggered measurements are practicable.

We grant you 2 years warranty and customized system solutions with modified hardware and software.

### Advantages of line cameras compared to line scanners:

- no opto mechanical Scanner
- high measurement speed up to 2000 lines/second
- use of uncooled infrared sensor arrays
- simultaneous measurement of all measurement points



### Selected technical features

Measurement uncertainty	2 K (object temperature < 100 °C) or 1 K + 1 % of measured value in °C <sup>1</sup>
Interfaces	Fast Ethernet, galvanically isolated digital inputs (trigger) and digital outputs (alarm)
Power supply	12 V to 36 V DC, approx. 7 VA
Camera housings	<ul style="list-style-type: none"> <li>• Standard compact housing IP54 "compact": aluminium, 85 mm (L) × 175 mm (W) × 107 mm (H), without optics and connections, weight approx. 1.6 kg</li> <li>• Standard compact housing IP54 "compact+": aluminium, 65 mm (L) × 160 mm (W) × 79 mm (H), without optics and connections, weight approx. 1.1 kg</li> <li>• Industry protection housing IP65 "protection": stainless steel, with air purge unit, water cooling and protection window, diameter 110 mm, length 280 mm, without mechanical mounting and connections, weight approx. 4.2 kg</li> <li>• Explosion proof and weather proof housing</li> </ul>
Operating temperature of the camera	-10 °C to 50 °C (without water-cooling), -25 °C to 150 °C (with water-cooling)



explosion proof housing (ATEX)



weather proof housing

**PYROLINE "protection"**  
with industry protection housing IP65

<sup>1</sup> 512N/256 Hz and HS 512N/2 kHz: measuring temperature range 1: 1 % of measured value in °C, measuring temperature range 2: 2 % of measured value in °C. <sup>2</sup> 512N, HS 512N

# For Non-Contact Measurement Of Temperature Profiles

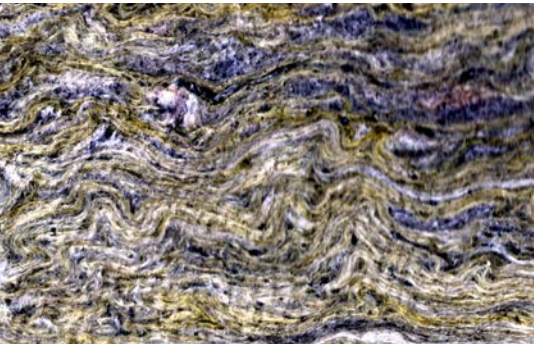

Camera type	Pixel	Temperature range <sup>1,2</sup>	NETD <sup>3</sup>	Spectral range
128LS/256 Hz	128 × 1	0 °C to 80 °C	0.2 K/0.5 K	<b>8 µm to 14 µm</b>  Wood, paper, plastics, gum, bulk materials, building material, textiles, food
128L/256 Hz	128 × 1	50 °C to 550 °C	0.5 K/1.5 K	
256L/256 Hz	256 × 1	50 °C to 550 °C	0.5 K/1.5 K	
128LS/512 Hz	128 × 1	50 °C to 550 °C	0.5 K/2 K	
256L/512 Hz	256 × 1	150 °C to 800 °C	0.5 K/2 K	
Optics with motor focus: 40°, 60°, 90°				



Camera type	Pixel	Temperature range <sup>1,2</sup>	NETD <sup>3</sup>	Spectral range
128G/256 Hz	128 × 1	450 °C to 1250 °C	1 K/3 K	<b>4.8 µm to 5.2 µm</b>  Glasses: float glass, container glass, glass bottles, glass melts
256G/256 Hz	256 × 1	450 °C to 1250 °C	1 K/3 K	
128GS/256 Hz	128 × 1	250 °C to 800 °C	1 K/3 K	
Optics with motor focus: 40°, 60°, 90°				

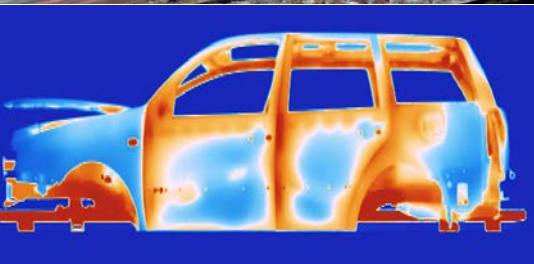

Camera type	Pixel	Temperature range <sup>1,2</sup>	NETD <sup>3</sup>	Spectral range
128M/256 Hz	128 × 1	450 °C to 1250 °C	0.5 K/1.5 K	<b>3 µm to 5 µm</b>  Building materials (clay, brick), metals (non-ferrous metals, rolled steel)
256M/256 Hz	256 × 1	450 °C to 1250 °C	0.5 K/1.5 K	
128MS/256 Hz	128 × 1	200 °C to 800 °C	0.5 K/1.5 K	
Optics with motor focus: 40°, 60°, 90°				



Camera type	Pixel	Temperature range <sup>1,2</sup>	NETD	Spectral range
512N/256 Hz	512 × 1	600 °C to 1500 °C, 1400 °C to 3000 °C <sup>4</sup>	< 1 K (600 °C) <sup>4</sup> ≈ 2 K (1400 °C) <sup>4</sup>	<b>0.8 µm to 1.1 µm</b>  Metals in high temperature range (steel, stainless steel, steel melts)
HS 512N/2 kHz	512 × 1	650 °C to 1500 °C, 1400 °C to 3000 °C <sup>4</sup>	< 1 K (600 °C) <sup>4</sup> ≈ 2 K (1400 °C) <sup>4</sup>	
Optics with motor focus: 9°, 13°, 19°, 36°, 51°, 90° <sup>4</sup> ... or 0.15 % of measured value in °C at 256 Hz respectively 2 kHz.				

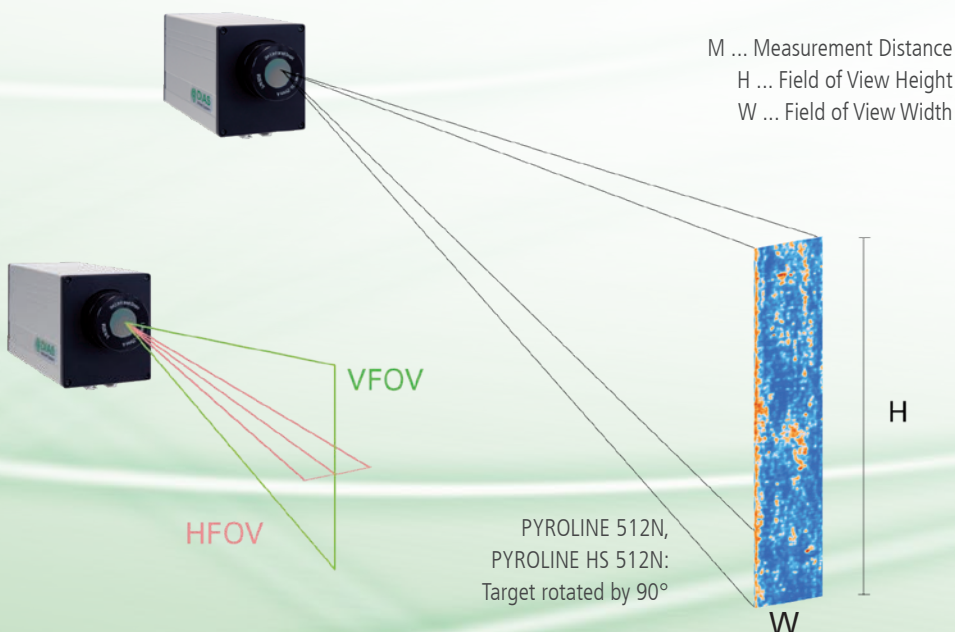

Optics variants			
VFOV × HFOV	M [m]	H [mm]	W [mm]
19° × 0.2°	1	352	3
	3	1060	8
	10	3530	28
40° × 0.3°	1	728	6
	3	2180	17
	10	7280	57
51° × 0.2°	1	960	3,8
	3	2880	11,3
	10	9600	37,5
60° × 0.5°	1	1160	9
	3	3460	27
	10	11500	90
90° × 0.9°	1	2000	16
	3	6000	47
	10	20000	156

<sup>1</sup> Others on request. <sup>2</sup> Specifications for black body radiator and ambient temperature 25 °C. <sup>3</sup> Noise equivalent temperature difference at 32 Hz and maximum measurement frequency.

# PYROLINE

## Dimensional drawing standard compact housing „compact“ (IP54)

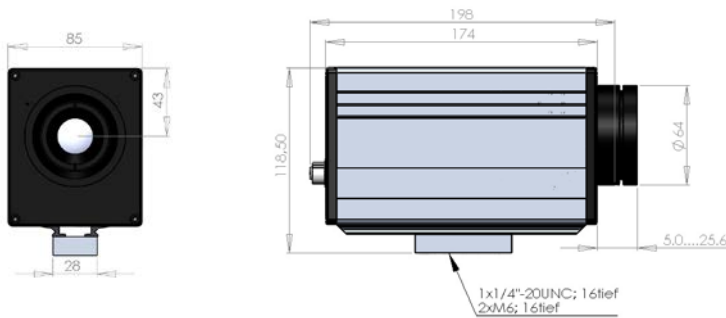

## Dimensional drawing industrial "protection" housing (IP65)

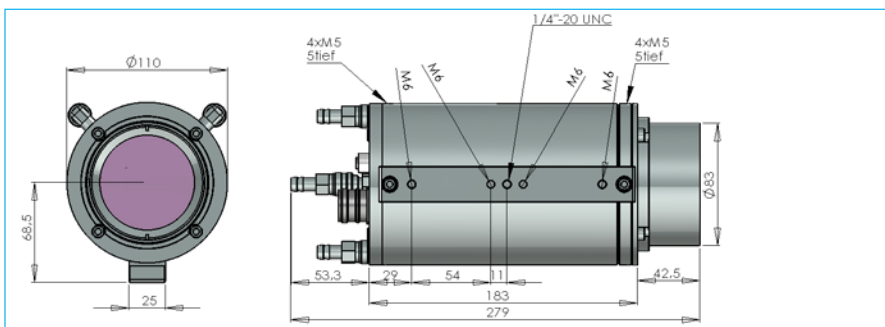

## Dimensional drawing standard compact housing „compact+“ (IP54)

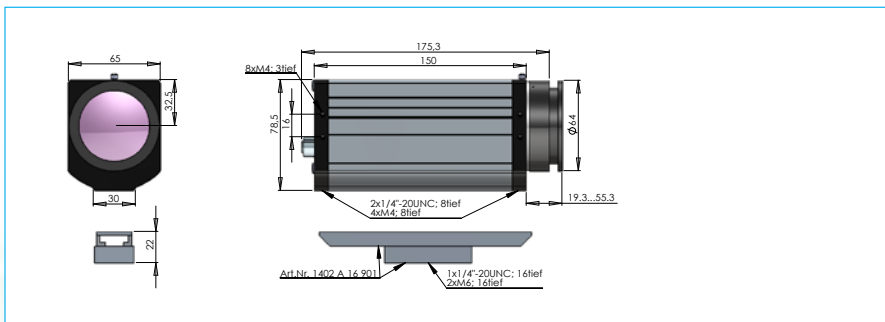

## Software

The powerful online software **PYROSOFT** for Windows® allows you to control the infrared line camera **PYROLINE**. Recording, viewing, manipulation and storage of the measured data are possible as well.

Special features are:

- real-time data recording
- definition of zones and monitoring of alarm thresholds
- analysis of trends
- data export (text, bitmap, video)
- process control via PROFIBUS, analog and digital inputs, outputs and other interfaces

A programming interface (Windows® DLL) is available for system integration.

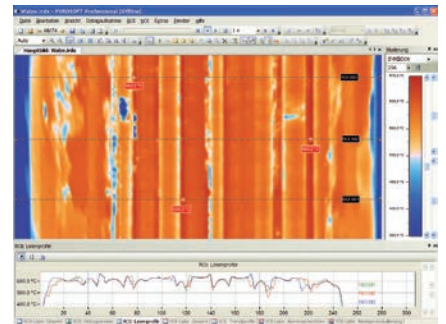

## Connectors



- Ethernet (LAN)**
- Infrared data in real-time with up to 2000 lines per second (TCP/UDP)
  - Web interface (status and image bar)
  - PYROSOFT software
  - Configuration for stand-alone operation

- |                |               |
|----------------|---------------|
| ➔ Power supply | Error signal/ |
| ➔ Trigger 1    | Alarm 1 ➔     |
| ➔ Trigger 2    | Synch signal/ |
|                | Alarm 2 ➔     |

**Inputs**

**Outputs**

**Customized terminal box**  
(with power supply, alarm relay, controller, media converter, ...)



Phone: +49 351 896 74-0  
 Fax: +49 351 896 74-99  
 Email: info@dias-infrared.de  
 Internet: www.dias-infrared.com

DIAS Infrared GmbH  
 Pforzheimer Straße 21  
 01189 Dresden  
 Germany

Technische Änderungen vorbehalten. Technical details are subject to change. 07.08.24  
 Image credits: DIAS Infrared GmbH, about:video.de / frisch bebügelt © Rainer Sturm, ICAPlants, Achim Hering, Marc Thuerbach, Wikimedia Commons, Lizenzier unter Creative Commons  
 Lizenz: by-sa-2.0-de, URL: http://creativecommons.org/licenses/by-sa/2.0/de/legalcode, Gas cutting of the hot metal", Copyright: Jordache, 2013, verwendet mit der Lizenz von Shutterstock.de