

# PYROVIEW 1600N and 1920N

High-resolution infrared cameras for temperature measurement up to 1800 °C



## Overview

Whether in quality control, process monitoring or process automation in the metal industry – the high-resolution PYROVIEW 1600N and 1920N thermal imaging cameras measure temperatures accurately and reliably. In order to minimize physically induced temperature measurement errors due to emissivity inaccuracies, the cameras operate at particularly short wavelengths of 0.8 µm to 0.9 µm. Even in fast processes or with rapid temperature changes, data is transmitted in real time.

In stationary industrial continuous operation measurement data is recorded with high spatial resolution on fixed or moving measurement objects. In this way production processes are monitored and controlled efficiently. The Gigabit Ethernet interface guarantees a data acquisition without loss and with no appreciable time delay up to 25 images per second.

Motorized focusable standard, telephoto and wide-angle infrared lenses allow flexible adaptation to different measurement object sizes, even at different measurement distances.

The infrared camera is either built in a small aluminium housing „compact+“ or in a stainless steel industry protection housing „protection“ that has a protection window, an air purge unit and an optional watercooling.

The modular Windows software PYROSOFT of the camera can be adjusted and extended to process-related requirements. The free software PYROSOFT Compact is delivered with every PYROVIEW infrared camera.



## Made by DIAS Infrared

DIAS Infrared headquartered in Dresden (Germany) develops and manufactures high-quality precision devices as well as system solutions for non-contact temperature measurement. Challenging projects are a welcoming motivation for us. The customers appreciate the robust design, outstanding accuracy, superb reliability and the high service standard of our devices.

# PYROVIEW 1600N and 1920N

High-resolution infrared cameras for temperature measurement up to 1800 °C

Technical data				
Device housing type	compact+		protection	
Device type	1600N	1920N	1600N	1920N
Measuring temperature range (NETD – Noise equivalent temperature difference) <sup>1</sup>	650 °C and 900 °C (< 2 K at 15 Hz, 700 °C) 750 °C and 1100 °C (< 3 K at 25 Hz, 800 °C) 850 °C and 1300 °C (< 3 K at 25 Hz, 950 °C) 900 °C and 1400 °C (< 4 K at 25 Hz, 1000 °C) 950 °C and 1500 °C (< 4 K at 25 Hz, 1100 °C) 1100 °C and 1800 °C (< 4 K at 25 Hz, 1300 °C)			
Spectral range	0.8 µm to 0.9 µm			
Aperture angle (HFOV × VFOV)	33°×25°, optional 50°×39°, 18°×13°	39°×22°, optional 59°×35°, 21°×12°	33°×25°, optional 50°×39°, 18°×13°	39°×22°, optional 59°×35°, 21°×12°
HD-Si-CMOS sensor	1600×1200 pixels	1920×1080 pixels	1600×1200 pixels	1920×1080 pixels
Measurement uncertainty <sup>1</sup>	2 % of the measured value in °C			
Measurement frequency	internal 25 Hz (15 Hz) <sup>2</sup>			
Response time	internal 80 ms (130 ms) <sup>2</sup>			
Interface	Gigabit-Ethernet (real-time, 25 Hz or 15 Hz), galvanically isolated digital input and digital output			
Connectors	round plug connector M12A (8 pin, power supply, digital input and output), round plug connector M12X (8 pin, Ethernet)		round plug connector M23 (16 pin, power supply, digital input and output), round plug connector M23 (RJ45, Ethernet)	
Power supply	10 V to 25 V DC, typical 5 VA			
Weight	approx. 1.6 kg		approx. 4.2 kg	
Housing	aluminium compact housing IP54, 65 mm (L) × 160 mm (W) × 79 mm (H), without optics and connectors		industry protection housing IP65, stainless steel, with protection window, air purge and optional water cooling, diameter 110 mm, length 280 mm (without mechanical mounting and connectors), 6 bar max. water pressure, 2 bar max. air pressure	
Operating temperature of the camera	-10 °C to 50 °C		-10 °C to 50 °C (without water cooling), -25 °C to 150 °C (with water cooling)	
Storage conditions	-20 °C to 70 °C, max. 95 % rel. humidity			
Software	control and imaging software PYROSOFT for Windows®, customized modifications on request			
Scope of delivery	infrared camera PYROVIEW, calibration certificate, manual, software PYROSOFT Compact			

<sup>1</sup> Specifications for black body radiators and ambient temperature 25 °C. <sup>2</sup> Measurement temperature range 650 °C to 900 °C.

## Optics variants (optics with motor focus)

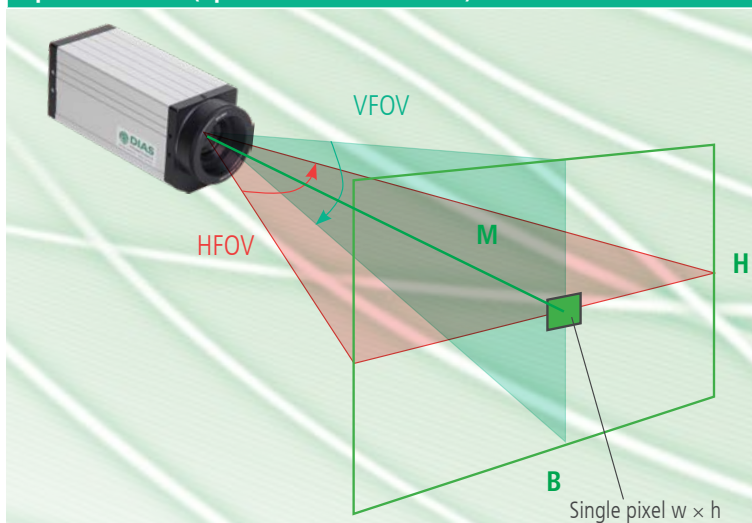

HFOV ... Horizontal Field Of View (horizontal aperture angle)  
 VFOV ... Vertical Field Of View (vertical aperture angle)  
 IFOV ... Instantaneous Field Of View (spatial resolution)  
 D ... Measurement distance

W ... Image width  
 H ... Image height  
 w ... Pixel width  
 h ... Pixel height

HFOV × VFOV	M [m]	W [m]	H [m]	w [mm]	h [mm]
IFOV					
50°×39°	1	0.94	0.70	0.6	0.6
	3	2.81	2.11	1.8	1.8
0.6 mrad	10	9.38	7.03	5.9	5.9
33°×25°	1	0.59	0.44	0.4	0.4
	3	1.76	1.32	1.1	1.1
0.4 mrad	10	5.86	4.40	3.7	3.7
18°×13°	1	0.31	0.23	0.2	0.2
	3	0.94	0.70	0.6	0.6
0.2 mrad	10	3.13	2.34	2.0	2.0
59°×35°	1	1.13	0.63	0.6	0.6
	3	3.38	1.90	1.8	1.8
0.6 mrad	10	11.25	6.33	5.9	5.9
39°×22°	1	0.70	0.40	0.4	0.4
	3	2.11	1.19	1.1	1.1
0.4 mrad	10	7.03	3.96	3.7	3.7
21°×12°	1	0.38	0.21	0.2	0.2
	3	1.13	0.63	0.6	0.6
0.2 mrad	10	3.75	2.11	2.0	2.0

# PYROVIEW 1600N and 1920N

High-resolution infrared cameras for temperature measurement up to 1800 °C

## Dimensional drawing

### Dimensions PYROVIEW 1600N and 1920N (compact+ housing)

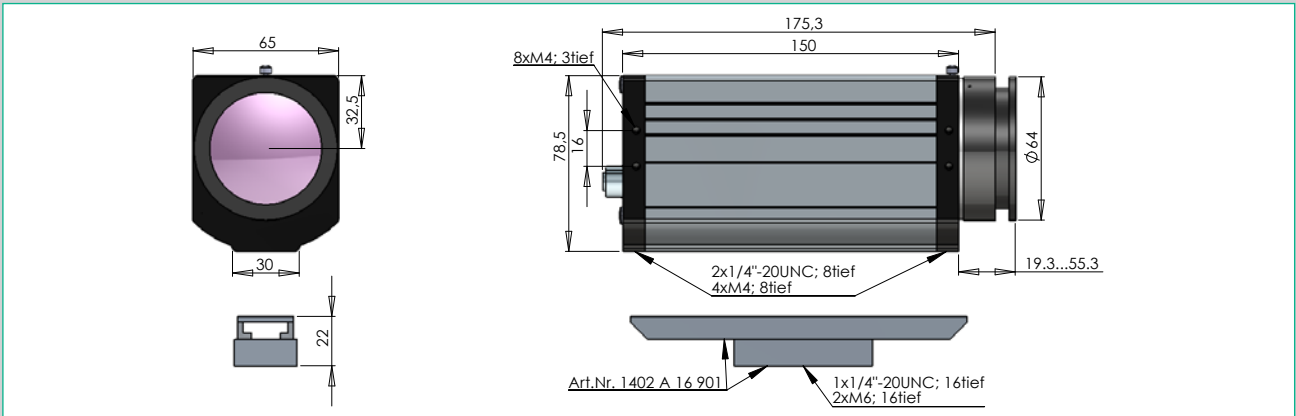

### Dimensions PYROVIEW 1600N and 1920N (protection housing)

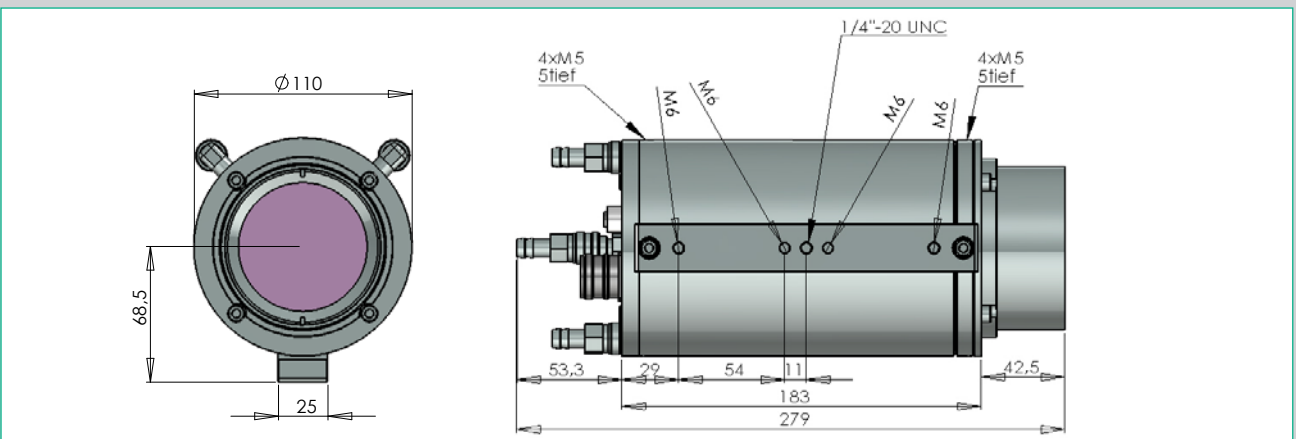

## Connectors



### Gigabit-Ethernet (LAN)

- Infrared real-time data up to 25 images per second
- GigE Vision® compatible
- PYROSOFT software

- Power supply
- Digital output, galvanically isolated
- Digital input, galvanically isolated

# PYROSOFT

Powerful online and offline software for DIAS infrared cameras

## PYROSOFT Compact

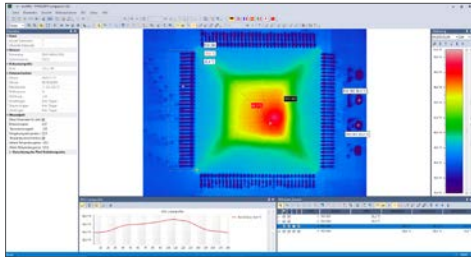

- Online data recording from a DIAS infrared camera
- Online data storage
- Opening and editing archived measurement data and sequences
- Bitmap and video export
- Definition of "areas of interest" (ROI): points, lines and rectangles
- Selection of color palettes and scaling including autodynamics
- Zoom functions with auto zoom, full screen view, rotation and tilt
- Creation of reports in Microsoft® Word format using the integrated report function
- Included with every camera

## PYROSOFT Professional

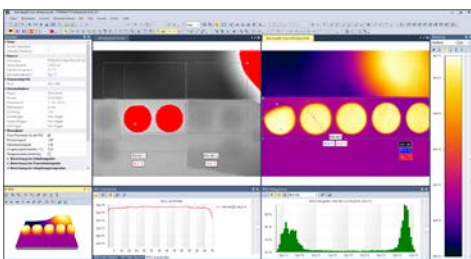

- Online operation for multiple cameras
- Online data recording – analyze, save and export data in real time
- Open and edit archived measurement data and sequences
- Multi-document structure for editing multiple documents
- Bitmap, video and text export
- Definition of ROI "regions of interest" and VOI "values of interest" with alarm evaluation, histogram and trend charts
- Reporting functions, multi-report for album files from multiple documents
- PYROSOFT Professional IO: additional bidirectional data interface via PROFIBUS, PROFINET, WAGO, Modbus, OPC, TCP socket or text file to process control systems, controllers and other applications

## PYROSOFT Automation

DIAS has developed the PYROSOFT Automation software solution for the integration of infrared cameras into automation processes:

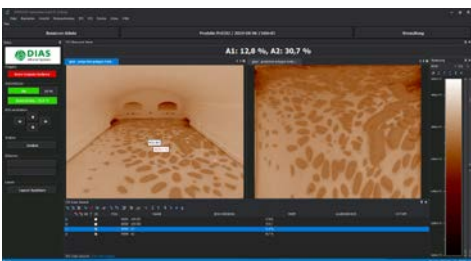

- Online functionality like PYROSOFT Professional IO
- Configurable interface, user rights and password management
- Manual or automatic product switching
- Display of status information and alarms
- PYROSOFT Automation SC: Synchronous data recording from up to 8 cameras, data is combined into a common image
- PYROSOFT Automation MC: Independent data recording and evaluation from up to 8 different cameras, display of individual and overview images of all cameras, status information, alarm messages and states of the IO outputs

## PYROSOFT DAQ

For users who want to integrate the camera into their own software environment, we offer our own DLL interface for DIAS infrared cameras:

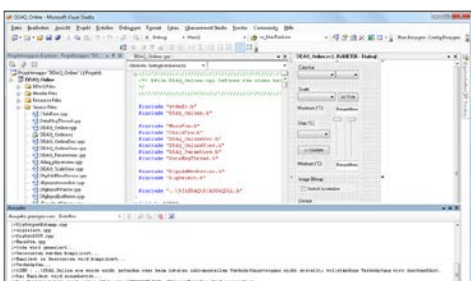

- API (32 and 64 bit Windows® DLL) for direct data access to cameras
- Support for the DIAS IRDX file format
- Setting recording parameters and measurement object properties
- Querying temperature measurements and camera information
- Bitmap functions for displaying color palettes and measurement values
- Online and offline functionality